

1	2	3	4	5				
No.	NAME	MATERIAL	DWG/MATL No.	CODE	Q'TY	SIZE	WEIGHT	REMARK
					0			

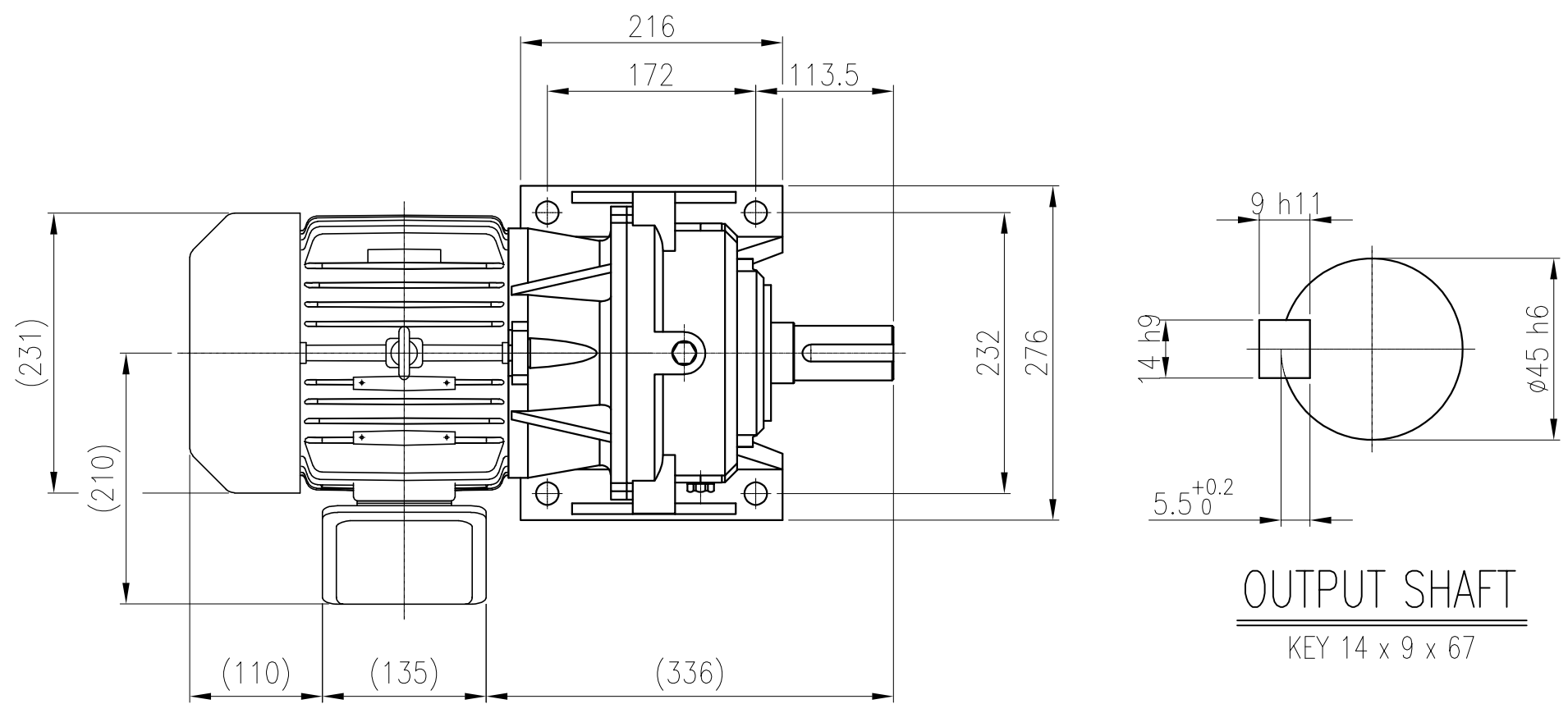

OUTPUT SHAFT
KEY 14 x 9 x 67

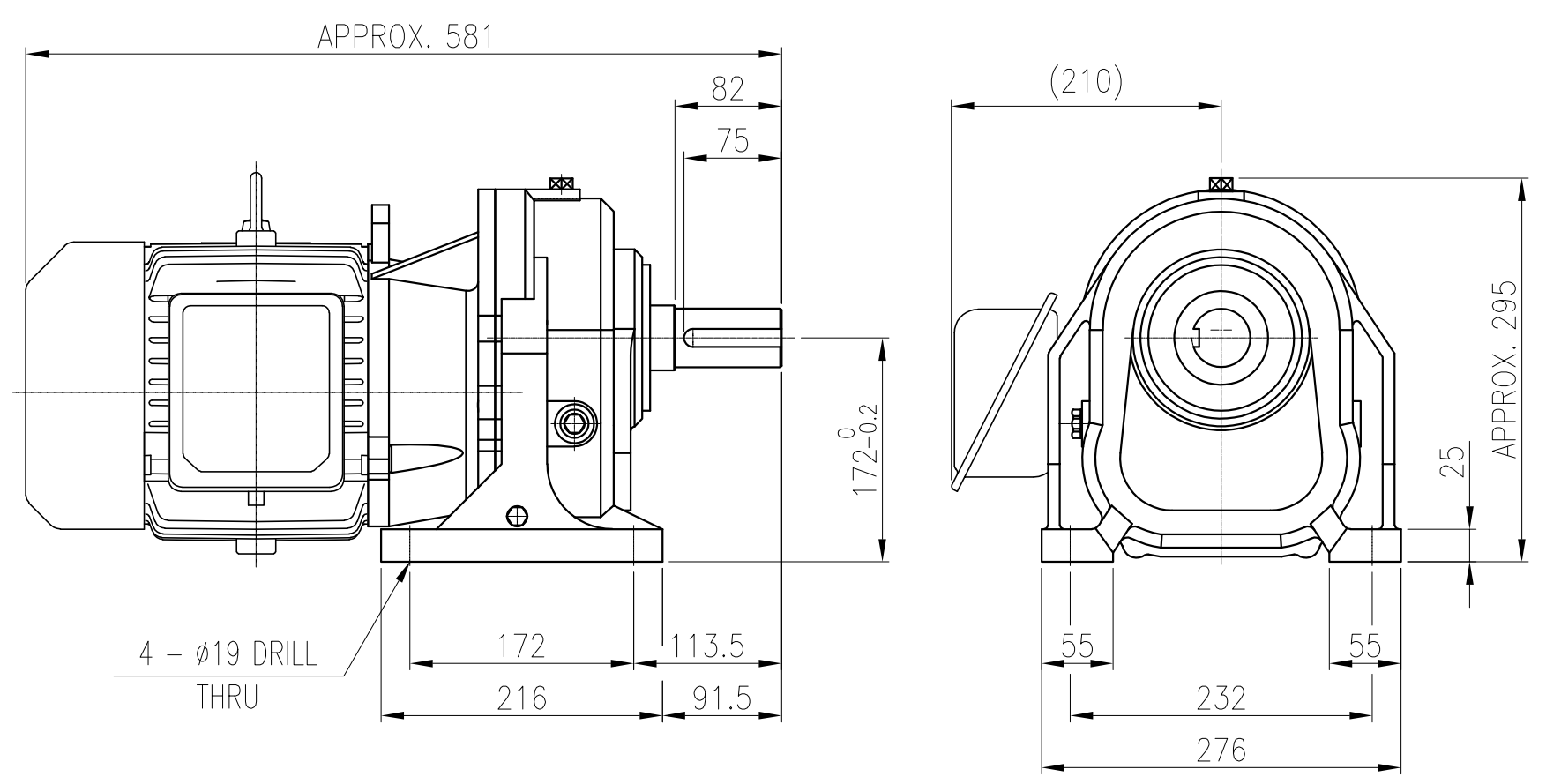

			BEARING		
	OIL SEAL		2ND PINION	6205ZZ 6305ZZ	GREASE : NLGI(EP)00
MOTOR SHAFT	D(M) 35 x 47 x 7		3RD PINION	- -	ABOUT 0.88 kg
OUTPUT SHAFT	D(M) 50 x 72 x 12		OUTPUT SHAFT	PM3530 6310ZZ	WEIGHT 81.78 kg

		DWG NAME		외형도 OUTLINE DIMENSION			
		DWG No.		EK2D007665H001		UNIT	mm
						SCALE	1:1
No.	DATE	DESCRIPTION of REVISION		DESIGNED	CHECKED	REVIEWED	APPROVED
				2019.01.21	2019.01.21	2019.01.21	2019.01.21
A4(210X297mm)		FORM		하슬기	문병선	박희성	홍원철
CE-14-0100-4A4		2013.11.20		HYOSUNG HEAVY INDUSTRIES		REVISION No.	00
TYPE		17Fr(3.7kW)_5~20:1_프리미엄		REF. No.		-	
						THIRD ANGLE PROJECTION	
						A	

이 도면상에 표시된 정보는 호성중공업(주)의 소유이며 당사의 사전 서면동의 없이 무단사용을 금합니다.